

# ENTERPRISE AND DEVELOPMENT TRADE COMPANY srl



Agenzia Italiana per il Commercio  
*Italian Agency for Trading*

**TECHNOLOGY  
QUALITY  
ASSISTANCE**

**AGRICULTURE TECHNOLOGY**  
Division



# why Enterprise...

*The companies and products that you will see in our catalogue, has been selected in years of experience in global trading.*

*Companies for wich we realize plants and we sold products all over the world.*

*COMPANIES WICH REPRESENT THE "REAL MADE IN ITALY".*

*The ENTERPRISE AND DEVELOPMENT TRADE COMPANY is in the conditions to grant logistic services all over the world and able to deliver products in any territory and solve any questions about this matter.*

*The historical relation and the name of our company allowed us to offer the best solution about timing, delivery and prices.*

Le aziende ed i prodotti che troverete nel nostro catalogo, sono selezionate da anni di esperienza nel commercio internazionale.

Aziende con le quali abbiamo realizzato forniture ed impianti in tutto il mondo.

AZIENDE CHE RAPPRESENTANO IL "VERO MADE IN ITALY".

La ENTERPRISE AND DEVELOPMENT TRADE COMPANY è inoltre in grado di garantire una logistica capace di consegnare ogni merce in ogni territorio risolvendo tutte le questioni necessarie.

I rapporti storici con queste aziende ed il nome che ci siamo creati, ci permette di offrire le migliori soluzioni di tempistica e di prezzo esistenti sul mercato.

*With my best regards*

*Thank you*

**Figaroli Girolamo**

# Introduction



**ENTERPRISE AND DEVELOPMENT**

**TRADE COMPANY srl**

di Figaroli Girolamo & C.

Via Garibaldi, 36

25010 ISORELLA (BS) ITALY

Mobile 334.8204934

info@figaroligirolamo.com

Skype: Figaroli Girolamo

www.enterpriseanddevelopment.com



# agricultural machinery

**ENTERPRISE AND DEVELOPMENT TRADE COMPANY srl**

Mobile 334.8204934 - [www.enterpriseanddevelopment.com](http://www.enterpriseanddevelopment.com)





# agricultural machinery



**SEMINATRICE  
DSG C  
2500/3000**

**SEED DRILL  
DSG C  
2500/3000**



Assolcatori a disco semplice  
con raschiaterre.

Furrow openers single disk  
with scraper.



Assolcatori a disco doppio  
con raschiaterre.

Furrow openers double  
disk with scraper.

**SEMINARE E CONCIMARE  
CONTEMPORANEAMENTE  
TO SOW AND TO FERTILIZE  
AT THE SAME TIME**



## CARATTERISTICHE GENERALI

### General Characteristics

Seminatrice per cereali a righe che effettua contemporaneamente la semina e la concimazione.

Dotata di due distribuzioni anteriore e posteriore indipendenti per semente e concime e di due variatori, risulta facilmente regolabile per le quantità da erogare. I due prodotti sono convogliati in un'unica tubazione e portati agli assolcatori.

Seed drill for cereals that sow and fertilizing at the same time. With two distributions one front and one rear independents for seed and fertilizer and of two variators, is easy to adjust for the quantity to supply. The two products come include in a sole tube and carry at the boots.

• Larghezza di lavoro Working width	Mt. 2,50	Mt. 3,00
• Capacità tramoggia/Seed hopper capacity Seme/Seed Concime/Fertilizer	Lt. 610 Lt. 355 Lt. 255	Lt. 755 Lt. 435 Lt. 320
• * N° max file Max row nbr	Nr. 17	Nr. 27
• N° standard assolcatori a stivaleto Standard "boot" furrow openers	Nr. 21	Nr. 25
• Cambio / Variatore continuo a bagno d'olio nr. 2 Oil immersed gear box with continuous transmission for seed distribution nbr. 2		
• Pneumatici Wheels	5.00-15	5.00-15
• Peso approssimativo (a stivaleto) Approximate weight (a boot)	Kg. 630	Kg. 700

\* WE RACCOMAND TO CHOOSE MINIMUM 19 ROW FOR THE 2,50 M. AS THE EUROPEAN STANDARD

### DOTAZIONI DI SERIE Standard Equipment

• Trazione singola 1 + 1 Single traction 1 + 1
• Raschiatterra a ruota Scraper for wheels
• Manovella e vaschetta prova seme Crank and seed collector basin for pressure regulation
• Erpice posteriore a parallelogramma con regolazione della pressione Back harrow with parallelogram for pressure regulation
• Dentino antintasamento sull'assolcatore Anti-block teeth on the furrow openers
• Pedana Foot board

### ACCESSORI A RICHIESTA Optionals

• Segnafile a disco manuale/idraulico Hydraulic or manual disk row marker
• Raspe rompitraccia n. 4 Trace breaker n. 4
• Contaettari elettronico Hectar counter electric
• Disco semplice Single disk
• Disco doppio Double disk
• Tram line Tram line

agricultural machinery





# agricultural machinery



***Produced in Italy***



***Agricultural District Brescia - Italy***





SEMINATRICE DSK 4500 / 6000



SEMINATRICE DSK 4500



Disco doppio con stabilizzatore e ruota regolazione profondità



Ruota di trasmissione



SEMINATRICE DSK 6000

Capacità tramoggia	Lt. 2700	Lt. 3400
Larghezza di lavoro	Mt. 4,50	Mt. 6,00
Larghezza di trasporto	Mt. 2,60	Mt. 3,00
Lunghezza	Mt. 7,00	Mt. 7,00
Altezza	Mt. 3,00	Mt. 3,00
File standard	Nr. 30	Nr. 48
File max	Nr. 30	Nr. 48
Peso	Kg. 5000	Kg. 6200
Potenza richiesta	KW 100/120	KW 150/180

agricultural machinery







agricultural machinery



Un ottimo investimento per il futuro!



### Anatre Non Reversibile

*Anatre Non Reversibile con Larghezza di Lavoro Variabile Idraulica*



### Non Reversible Ploughs

*Non Reversible Ploughs with Variable Working Width*



TECHNOLOGY  
QUALITY  
ASSISTANCE



ISO 9001:2000 - Cert. N° 3228



# VARIABLE WORKING WIDTH L.V.



Mod. AQ 406 LV

Hydraulic variable working width reversible ploughs are characterized by a very strong frame made with the best steels and a technically advanced shape.



BOCCOLE ANTIRUBA



RICUREZZA MECCANICA

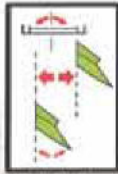

LARGHEZZA LAVORO VARIABILE

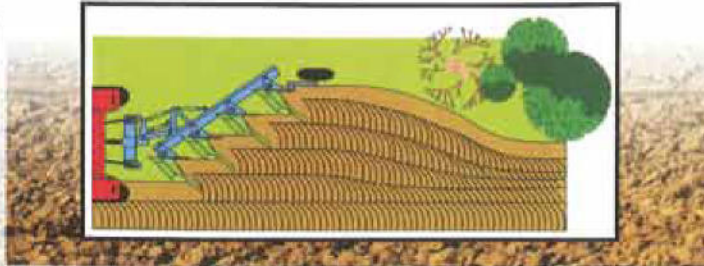

## Performances:

Variable width ploughs are able to grant a continuous set-up of bodies working width, 1st body inclusive. In-fact the arm holding the tools change automatically the soil entrance of both the 1st body and the rear ones, this will avoid waste of time to regulate the plough.

Very large set-up of working width among the bodies:  
From 20 to 70 cm depending on models.

A very large interbody clearance/ height can grant a perfect ploughing.

All relevant movements are carried out using materials thermally treated fitted on interchangeables bushing also equipped of grease cup.

The modular structure of this plough allow to add or take out the last body very easily.

A perfect lining of the plough with the truck is granted by an haulage steering and self centering bar.



agricultural machinery







# agricultural machinery

Copertura scorrevole per evitare la fuoriuscita di materiali  
Sliding cover to prevent spillage of materials



## G 100/140/200

con cassone Dumper  
Rounded and conical  
(DOMEX) body/caisson



## GENIUS

Scaricare senza ribaltare!  
Unico nel suo genere!  
Unloading without tipping!  
Unique in its class!





## RIMORCHI MONOASSE TIPO RMN

A RUOTE SEMPLICI, CON E SENZA GRU,  
RIBALTABILI TRILATERALI, SPONDE IN LEGA LEGGERA  
o IN LAMIERA D'ACCIAIO



Dati tecnici Serie RMN

Tipo	Omologato q.li	Dimensioni m	Tara Kg	Portata effettiva Kg	Pneumatici
G35RMN	35 lordi	3,00x1,80x0,50	1000	3600	10.075x15 10 PR
G40RMN	50 lordi	3,20x1,90x0,50	1100	4500	11.580x15 10 PR
G50RMN	50 lordi	3,50x2,00x0,50	1200	5500	11.580x15 12 PR
G60RMN	60 lordi	4,00x2,00x0,50	1400	6500	13.065x18 16 PR
G60RMNS	60 lordi	4,30x2,30x0,50	1600	8000	15R22.5 seminuove

## RIMORCHI TANDEM TIPO FORESTAL

A RUOTE MOTRICI ANTERIORI,  
BALESTRE A BILANCINO, CON E SENZA GRU



Dati tecnici Serie Forestal

Tipo	Dimensioni	Grù girevole 360° e ritorno	Portata braccio tezo Kg	Lunghezza braccio cm	Pneumatici
FORESTAL 120 omologato q.li 120 lordi	4,50x2,20x0,50	G3 TE	700	430	13.065x18-16 PR nuove
FORESTAL 140 omologato q.li 140 lordi	5,00x2,20x0,50	G4 TE	800	460	G 20- 20 PR industriali seminuove



Dati tecnici Serie MFA

Tipo	Omologato q.li	Dimensioni m	Tara Kg	Portata effettiva Kg	Pneumatici
MFA 27	35 lordi	2,60x1,60x0,40	700	2500	10.075x15 8 PR
MFA 35	35 lordi	3,00x1,80x0,50	800	3500	10.075x15 10 PR
MFA 40	50 lordi	3,20x1,90x0,50	900	4000	10.075x15 10 PR
MFA 50	50 lordi	3,50x2,00x0,50	1000	4500	11.580x15 14 PR
MFA 60	60 lordi	4,00x2,00x0,50	1200	5500	11.580x15 14 PR
MFA 60S	60 lordi	4,30x2,30x0,50	1500	6500	15 R22.5 seminuove

agricultural machinery







# agricultural machinery

MACCHINE AGRICOLE

# REMAC



REMAC 300



ISO 9001:2000 - Cert. n° 2278







# agricultural machinery







## DESPEDREGADORAS DE DESCARGA AL SUELO ROCK PICKERS UNLOAD TO GROUND EPIERREUSES DE DÉCHARGE AU SOL

- Despedregadoras de descarga simple y rápida.
- Rock pickers unload simple and fast.
- Epierreuses à déchargement simple et rapide.

La despedregadora se construye para trabajar con cardán y transmisión por correas o bomba hidráulica y transmisión hidrostática (ver pág. 14).

The rock picker is manufactured with drive shaft and belts transmission or with hydraulic pump and hydrostatic transmission (see page 14).

L'épierreuse est conçu avec prise de force et transmission par courroies ou pompe hydraulique et transmission hydrostatique (voir page 14).



Despedregadora descargando al suelo  
Rock Picker unloading to ground  
Déchargement du épierreuse au sol



Transmisión por correas y cardán.  
Belts transmission and drive shaft.  
Transmission par courrois et prise de force.



Transmisión hidrostática.  
Hydrostatic transmission.  
Transmission hydrostatique.

DAM-5

DESPEDREGADORAS DE DESCARGA AL SUELO  
ROCK PICKERS UNLOAD TO GROUND  
EPIERREUSES DE DÉCHARGE AU SOL



agricultural machinery







Agriculture  
Technologies

## VITTORIA Universal



agricultural machinery

Model	UNIVERSAL E-2										
	2,25	2,25	2,50	2,50	2,50	3,00	3,00	3,00	4,00	4,00	4,00
Working width m	2,25	2,25	2,50	2,50	2,50	3,00	3,00	3,00	4,00	4,00	4,00
Numbers rows	15	17	18	19	21	21	23	25	29	31	33
Min. distance betw. the rows mm	140	122	138	130	118	143	131	120	138	129	120
Hopper capacity kg	345	345	390	390	390	495	495	495	670	670	670
Weight of the drill when empty kg (trailing shoe coulters)	392	404	435	447	459	525	537	549	705	717	729
Weight of the drill when empty kg (single disks)	438	451	490	503	516	590	603	616	795	808	821
Weight of the drill when empty kg (double disks coulters)	500	520	560	580	600	650	670	690	870	890	910
Tyres	500 - 15										
Height m	1,4										
Overall dimensions m	2,19	2,19	2,49	2,49	2,49	3,07	3,07	3,07	4,07	4,07	4,07

*We recommend to choose minimum 19 row for the 2,50 mt; as the European standard*





■ The Vittoria Universal series E-2 seeder is a new, modern concept machine the construction of which is the result of our past experience and ongoing manufacturing efforts in the area of seeding machinery.



Distribuzione per semi grandi e piccoli.  
Distribution for large and small seeds.  
Distribution pour petites et grosses graines.  
Distribución de semillas grandes y pequeñas.  
Verteiler für grosse und kleine Samen.



Regolazione profondità.  
Depth adjustment.  
Réglage de la profondeur.  
Regulación de la profundidad.  
Tiefeneinstellung.



Catena di trasmissione.  
Chain drive.  
Trasmissione par chaîne.  
Cadena de transmisión.  
Kettenübertragung.



■ Fixed chamber with rollers and very compact, Trotter 100 offers technological solutions and performance of the highest level. A polyvalent machine, always ideal everywhere: on sloping ground in hills or foothills; with all types of forage (alfalfa and hay silage), with straw and even BRUSHES (ideal for handling BIOMASS).

agricultural machinery







# agricultural machinery



## BIG STORM

Zweirad-Modellen, unterscheidet sich aber von diesen völlig durch ihren besonderen Bau, der sie zum haltbarsten Gerät überhaupt macht. Die folgende technische-bauliche Bestandteile sind von besonderer Relevanz: Ein gegenüber den Zweirad-Standard-Grabenfräsen größer dimensionierter Rahmen; Untersetzungsgetriebe in integrierter kompakter Einheit (Vorgelege und Antrieb) mit doppelter Mittelwelle, um die Gefahr gefährlicher Rückstöße zu vermindern und die Maschine zu verstärken; Vorgelegenheit im Untersetzungsgetriebe, hinter der Antriebsseinheit, damit die Ausrichtung der Kardanwelle gewährleistet ist; Rotoren mit doppeltem Rad, unterteilt in 4 Abschnitte, um ggf. Reparaturen zu erleichtern, ohne den ganzen Rotor ausbauen zu müssen; Gekrümmte Messer für höchste Leistung bei jeder Bodenbeschaffenheit.

### Канавокопатели двухроторные BIG STORM

Это самый большой канавокопатель в мире. Он относится к двухроторным канавокопателям, но полностью отличается от них своей специальной конструкцией, делающей машину абсолютно устойчивой. Особое значение имеют следующие технико-структурные компоненты: Усиленная рама, по сравнению с обычными двухроторными канавокопателями; Редуктор из литого моноблока (привод и трансмиссия) с двойным центральным валом понижают риск обратного удара и усиливают машину; Группа внутреннего привода от редуктора и заднего от группы трансмиссии, для обеспечения большей согласованности карданного вала; Роторы с двойным диском разделены на 4 сектора для упрощения возможного ремонта без необходимости демонтажа всего ротора; Изогнутые ножи для максимальной отдачи при любом типе почвы. Также протестирован на камнях 30 см в диаметре и может рыть канал 150 см глубиной за один проход.

Mod./Mod.	P kW CV/HP	Hp/h.p.	Km/h km/h	Kg/lt	Größenmaß/Размеры рамы			
					A	B	C	*
BIG STORM	1000	150/200	0,4 - 0,7	2000	40	156	145	22°
BIG STORM	1000	150/200	0,4 - 0,7	2050	40	215	145	30°

\* Steigungswinkel / Наклон



Arbeitsabschnitt - Раб.секция

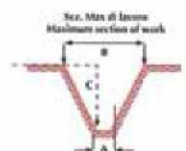

Max. Max. di lavoro  
Maximum section of work





■ Combined machine ideal for picking up green products (first-crop hay, ryegrass and alfalfa). The product is wrapped after pressing preventing further possible contamination by contact with the ground.



# ROUND BALERS



# agricultural machinery







## HAY BALERS

The traditional “LERDA” baler has been present on the markets for over 50 years. Improved over the years, it is now produced in a wide range of models.

It has proven to be the ideal baler for harvesting forage, rice and wheat straw, maize plants and the like in 32x42 or 36x46 cm bales, from 80 to 100 cm in length.

Small-dimension and low-weight models can be fitted to low power tractor ideal to harvest in mountain or hill areas.



Modello	800 L	900 L	1000 L	1100 L	1300 L	1100 P	1500 P
Larghezza lavoro raccogliitore cm	75	90	105	120	135	120	150
Camera di compressione cm	32 x 42	32 x 42	32 x 42	32 x 42	32 x 42	36 x 46	36 x 46
Carreggiata cm	135	150	165	180	180	180	180
Ingombro in larghezza cm	150	165	180	200	210	200	225
Altezza totale cm	139	139	139	139	139	142	142
Massa della macchina kg	900	920	960	1000	1050	1200	1280
Ruota sinistra	6.00/16	6.00/16	6.00/16	6.00/16	10.0/80-12	10.0/80-12	10.0/80-12
Ruota destra	165-70-13	165-70-13	165-70-13	165-70-13	165-70-13	165-70-13	165-70-13
Potenza assorbita	20/27	20/27	20/27	20/27	24/32	27/36	40/54





***Produced in Italy***



***Agricultural District Brescia - Italy***

**agricultural machinery**







# agricultural machinery



**CODAF**  
ZOOTECNIC & POULTRY  
EQUIPMENT MANUFACTURES

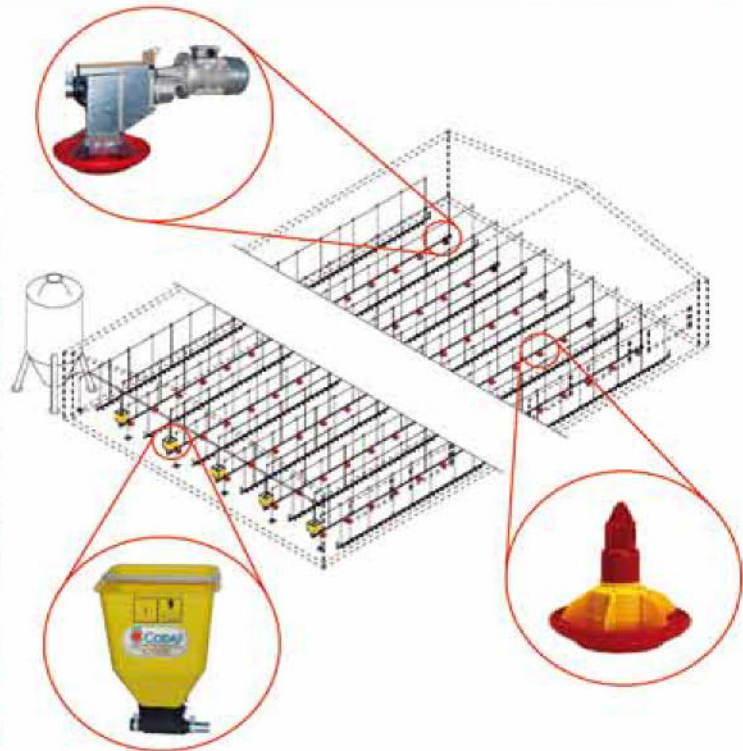

Feeding pans are attached to a manual or automatic suspension plant centralised on each line, which allows height adjustment during the growing phases of the animals and feed is automatically sent to the auger from the silos and collected in the containment hopper. Then it's distributed in the feeding plates with a regulator by means of a tube with a distribution spiral inside it. This is moved by a geared motor towing group situated at the end of the line. Feeding plates are filled in sequence starting from the one nearest to the containment hopper up to the last one.





EURO  
SILOS  
S I A P



Vertical bolted fiberglass silos suitable to store poultry feed with conveying system for flex auger and EMERALD silo outlet .



**FLOUR FOOD STORAGE  
AND DOSAGE FACILITY**

*agricultural machinery*





# *Mobile Trockner - Séchoirs mobiles*

Mobiler Sojatoaster im Einsatz

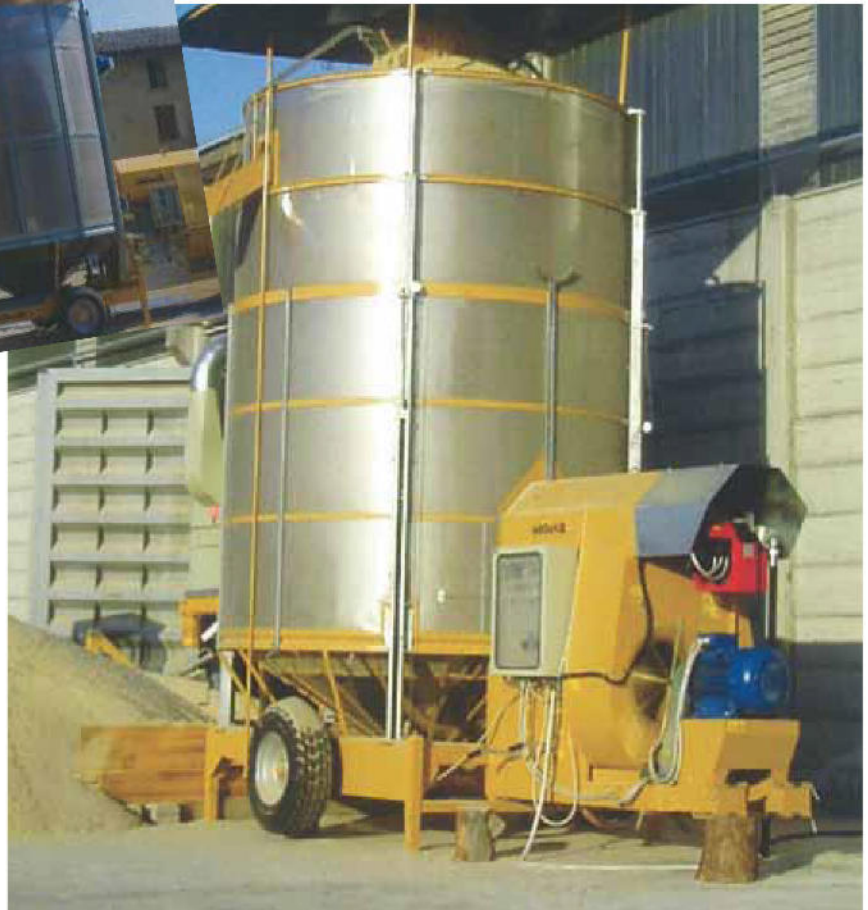

agricultural machinery





**OLDENHUIS & PRINSEN**

**NEWS  
NEUHEITEN  
NOVITEITEN**



**SMART**

NEW Visser AL 2400 BK VRS



**SYMPPLICITY**

NEW Visser AL 2800 BK MULTI CLEANER



**SPECIAL**

NEW NON-STOP SPIRAL ROLLERS CLEANER

**STRONG**



**agricultural machinery**







# agricultural machinery



Carrot harvester ALINA ECO is suitable for small and middle areas of vegetables. Harvester is equipped with digging function, haulm ripping and conveyor to transmit crops on the trailer. The harvester has many modern end functional technical solutions. Guarantees high quality of crops and effective picking.



# VSS AMAC

LEVERINGSPROGRAMMA



Uienlader



Uien loofklappers



Uien voorraad rooier



Twee rijige aardappel Voorraadrooier



Vier rijige aardappel Voorraadrooier



Aardappel loofklappers



Amac spare parts

*"De nieuwe generatie  
landbouwmachines"*







# agricultural machinery



ZEMA I-TRÄGERFAHRZEUG mit Erntetechnik ZEMA-Erntebalken



ZEMA-TRÄGERFAHRZEUG mit Erntesystem



ZEMA I-TRÄGERFAHRZEUG mit Erntetechnik ZEMA-Rotation



ZEMA-TRÄGERFAHRZEUG komplett aufgeklappt



ZEMA I-TRÄGERFAHRZEUG mit Erntetechnik ZEMA-Erntefix



ZEMA-TRÄGERFAHRZEUG ohne Anbaugerät







# agricultural machinery

## ROOT VEGETABLES HARVESTERS ALINA SUPERNOVA



Carrot harvester ALINA SUPERNOVA is suitable for high performance of crop. It can work with tractors with power 80 HP and more and also with different kinds of trailers. Harvester ALINA SUPERNOVA works perfectly on every areas of vegetables. The modern end functional technical solutions guarantee high quality of crops and effective picking. Harvester is equipped with digging function, haulm ripping and conveyor to transmit crops on the trailer. Independent hydraulic system.



Vollerntemaschine für Wurzelgemüse ist für große Ernteleistung geeignet. Arbeitet mit Schlepper mit der Leistung 80KM und mehr, wie auch mit allen anderen Anhängern. Sie eignet sich ausgezeichnet für jede Landwirtschaft. Moderne und funktionelle Konstruktionslösungen garantieren hohe Erntequalität und effektive Arbeit. Die Maschine ermöglicht: Roden von Wurzeln, Abreißen von Kraut und Förderung auf den Anhänger. Unabhängiges hydraulisches System.



Комбайн для уборки корнеплодных, приспособлен для большого по производительности урожая. Работает совместно с тракторами мощностью 80 л.с. и выше, а также всякого типа сельскохозяйственными прицепами. Совершенно проверяется в каждом хозяйстве. Современные и функциональные конструкционные решения гарантируют высокое качество уборки и эффективную работу. Снабжен функциями выкапывания, обрывания ботвы и транспортером на прицеп. Полностью независимая гидравлическая система.



### TECHNICAL DATA

Output  
Accuracy of harvest  
Lifting height of the conveyor  
Number of rows  
Tractor power demand  
Weight



### TECHNISCHE DATEN

Leistung  
Erntegenauigkeit  
Höhe der Förderung von Möhren  
Zahl der Reihen  
Arbeit mit dem Schlepper  
Nettogewicht



### ТЕХНИЧЕСКИЕ ДАННЫЕ

Производительность  
Точность уборки  
Высота подъема моркови на транспортере  
Число убираемых рядов  
Потребность в мощности  
Вес



TECHNICAL DATA	TECHNISCHE DATEN	ТЕХНИЧЕСКИЕ ДАННЫЕ	
Output	Leistung	Производительность	0.08-0.12 ha/h
Accuracy of harvest	Erntegenauigkeit	Точность уборки	98%
Lifting height of the conveyor	Höhe der Förderung von Möhren	Высота подъема моркови на транспортере	3.65 m
Number of rows	Zahl der Reihen	Число убираемых рядов	1
Tractor power demand	Arbeit mit dem Schlepper	Потребность в мощности	80 HP
Weight	Nettogewicht	Вес	1800 kg





#### Standard equipment of the harvester

- lengthened picking unit suspended on the bracket that is attached to the tractor's body,
- 3-element, wide conveyor for transporting carrot to a trailer; maximum lifting height: 3.65 m, with the possibility of smooth adjustment within the whole adjustment range; high conveyor enables unloading carrots to box-pallets arranged in two rows on each trailer
- regulated left wheel of the harvester that enables working on the ridges of the following spacing: 67.5 and 75.0 cm
- maintenance-free solution of the drives for haulm removing module and catching belts
- **complete internal hydraulics** for driving the working units and for the hydraulic cylinders
- **active shaking device for soil removing** – enables good cleaning of carrots before feeding them to the conveyor.
- a cooler with a thermostat – as a standard



#### ADDITIONAL EQUIPMENT

- automatic adjustment of haulm gripping height (1)
- conveyor for cleaning crops (2)
- rotary haulm gatherers (3) (rotary pick up devices)
- radio control for wide conveyor
- other, according to sales offer



#### Standardausrüstung der Vollerntemaschine Alina Supernova

- verlängerter Sammelsatz der Erntemaschine, an dem Tragarm des Maschinenrahmens angehängt
- 3-gliedriger, breiter Förderer, Hebehöhe beträgt 3,65 m mit Möglichkeit der Regulierung im ganzen Umfang, ermöglicht Schüttern der Möhren in Palettenkisten, die in 2 Reihen auf jedem Anhänger stehen
- regulierte Spurweite des linken Laufrades der Erntemaschine ermöglicht die Arbeit in Reihen mit Abstand von 67,5 und 75,0 cm
- neuer Antrieb des Abreißmoduls und Krautgreiferbänder, bedürfen keiner Bedienung
- volle innere Hydraulik zum Antrieb der Arbeitssätze und der Stellmotoren
- aktiver Trockenreiniger – reinigt Möhren, bevor sie auf den Förderer gefördert werden
- Kühler mit Thermostat – Standard



#### ZUSATZAUSRÜSTUNG

- Automatische Steuerung der Greifhöhe des Krautgreifers (1)
- Förderer für Trockenreinigung von Möhren (2)
- drehbare Unterfangsgeräte (3)
- Funksteuerung für breiter Förderer
- Anderes, nach aktuellem Preisangebot



#### Стандартное оборудование комбайна ALINA SUPERNOVA

- удлинённый собирающий узел, подвешен на кронштейне, прикрепленном к корпусу трактора,
- состоящий из 3 элементов транспортер; макс. высота подъема - 3,65 м с возможностью плавной регулировки в полном объеме; благодаря высокому транспортеру возможно сыпание моркови в пластиковые контейнеры, установлены в двух рядах на каждом прицепе,
- расстановка левого ходового колеса комбайна регулируется, комбайном можно въехать в рядовые борозды расстановки 67,5 и 75,0 см,
- новое решение приводов модуля обрывания и ремней схватывающих за ботву, не требующее никакого обслуживания,
- активный стряхиватель земли – благодаря ему хорошо очищается морковь перед перемещением ее на транспортер,
- маслоохладитель с термостатом в стандарте.



#### ДОБАВОЧНОЕ ОБОРУДОВАНИЕ

- модуль автоматической регулировки высоты схватывания за ботву (1)
- доочищающий транспортер очищающий морковь с остатков земли (2)
- вращательные подборщики ботвы (3)
- радиоуправление для транспортера
- другое, по актуальному торговому предложению







# ODENBERG HALO

The ODENBERG halo is the latest advancement in sensor based optical sorters for a high performance sort/grade on quality, size and for food safety. The ODENBERG halo combines intelligence with advanced control to provide sort flexibility and accuracy in a reliable, long life, compact sorter.



## BENEFITS OF THE HALO

- Reduces labor requirements up to 80%.
- Faster pack, increased throughput up to 25%.
- Increased yield.
- Lower operational costs
- Fast payback on investment.

## PROCESSOR APPLICATIONS

- Potato (skin on & peeled)
- Carrot
- Peach (halves)
- Pear (halves)
- Tomato
- Green Bean
- Citrus (Oranges, Mandarines, etc)
- Onion
- Apricots

## FRESH/PACK APPLICATIONS

- Potato (salad / small)
- Potato (main crop & large)
- Potato Russet
- Carrots & Parsnips
- Pickles, Cucumbers, Gherkins
- Onion
- Tomato
- Sweet Potato

## DETECTION

The ODENBERG halo uses top and bottom sensor banks to view each individual object 'in flight' using a combination of LED, CCD camera and NIR (Near Infra Red) to perform targeted spectroscopy with 1 mm precision. This advanced system views and analyses visible attributes (colour, shape, blemish, foreign material, etc.) as well as those difficult to see or 'invisible' defects to the product composition. The result is a highly accurate, flexible and controllable sort.

## REJECTION

Gentle product handling is assured by design; the 1st grade produce gently pass through the machine while 2nd & 3rd grade are redirected into individual streams by intelligent finger ejectors with precision and accuracy. More grading options are also available.

Gentle product handling is assured by design



The HALO's NIR optical sensors sort carrot product for shipment.



## WORKING PRINCIPLE

The product is spread uniformly onto the infeed belt and will be scanned by cameras on both sides. A few milliseconds later one type of material will be rejected by intelligent finger ejectors, positioned at the end of the infeed belt, while the other produce continue their way along the sorting line.

- 1 Infeed (unsorted)
- 2 Full width LED, CCD camera and NIR sensors (both sides viewed)
- 3 Intelligent finger ejectors
- 4 Gentle handling conveyer chutes (optional)

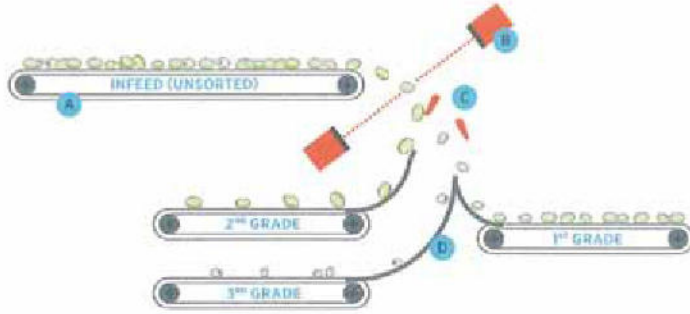

## 1 HIGH CAPACITY & LOW MAINTENANCE

High capacity and low maintenance are guaranteed by a simple belt feed system. This keeps installation and running costs low and reduces the risk of stoppages.

## 2 FLEXIBILITY & GENTLE HANDLING

Flexibility and gentle handling are given by design. Accept product pass through the sorter while intelligent low wear ejectors manage additional grades.

## 3 QUALITY CONTROL & FEEDBACK

Quality control and feedback are secured by the intuitive touch screen. Dashboard information on sort and line performance gives a highly detailed view of efficiency with data/trends on flow, grades/reject rate, etc.



## 4 CONSISTENT LONG LIFE ACCURACY

Consistent long life accuracy even on subtle color defects is provided by LED sensor technology. The 'off-belt' view guarantees a clear view and low maintenance.

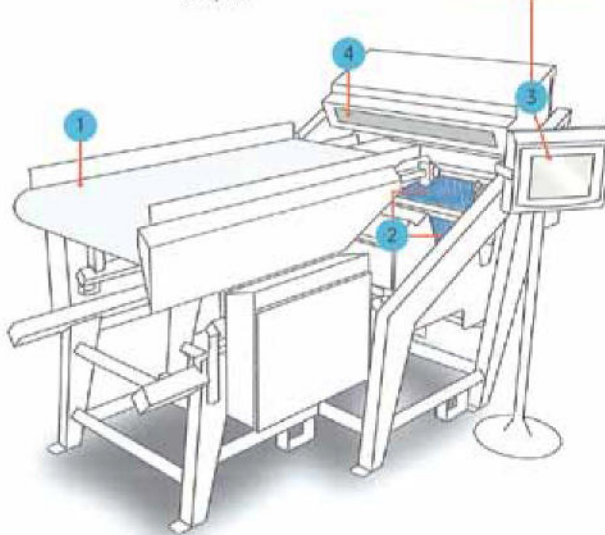
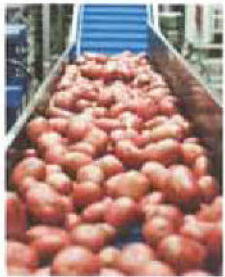

## ADVANCED SORTING PARAMETERS

- 1 Detailed Size / Geometry
- 2 Detailed Shape
- 3 Subtle Color
- 4 Subtle Defect
- 5 Subtle Blemishes
- 6 Damage
- 7 Foreign Material

## DIMENSIONS AND SPECIFICATIONS

Model	Dimensions				Utilities			Capacity
	Width	Length	Height	Infeed Belt	Power	Air	Water (min)	Max Capacity (kg/h)
<b>HALO 500</b>	1350 mm (53")	3750 mm (147")	2190 mm (83")	500 mm (20")	3.3 kVA	70 l/min	1.2 l/min	14,000
<b>HALO 1000</b>	1850 mm (73")	3750 mm (147")	2190 mm (83")	1000 mm (40")	3.3 kVA	120 l/min	2.0 l/min	30,000
<b>HALO 1500</b>	2350 mm (93")	3750 mm (147")	2190 mm (83")	1500 mm (60")	3.3 kVA	180 l/min	2.5 l/min	50,000
<b>HALO 2000</b>	2650 mm (102")	3620 mm (150")	2190 mm (83")	2000 mm (80")	3.3 kVA	240 l/min	3.0 l/min	70,000





# agricultural machinery

Lutrasil® Pro,  
die neue Generation von Vliesstoffen für den  
professionellen Gartenbau!

**Lutrasil®**  
Pro



Lutrasil® Pro garantiert optimalen  
Ernteertrag:

- Exzellente Produkthaltbarkeit, Festigkeit und höchster Reißwiderstand
- Elastisches Vlies nimmt Windkräfte auf
- Schützende Klimabarriere für jede Kultur
- Hervorragender Wasserdurchgang reduziert Wasserspeicherung im Vlies und damit Schlagschäden
- Optimaler Schädlingsschutz
- Gleichmäßige Temperatur- und Feuchtigkeitsverteilung

Lutrasil® Pro bietet für alle Anwendungen  
das richtige Produkt:

- Unterschiedliche Gewichte
- Praxisübliche Breiten und Längen
- Mehr als 80 Standardartikel auf Lager
- Kurzfristige Lieferzeit ab Lager für Standardartikel
- Sonderanfertigungen erhältlich

**NEU:**

Ab sofort größere Rollenlängen bei 2 m  
Rollenpackmaß!







# agriculture equipment

**ENTERPRISE AND DEVELOPMENT TRADE COMPANY srl**

Mobile 334.8204934 - [www.enterpriseanddevelopment.com](http://www.enterpriseanddevelopment.com)





# agriculture equipment

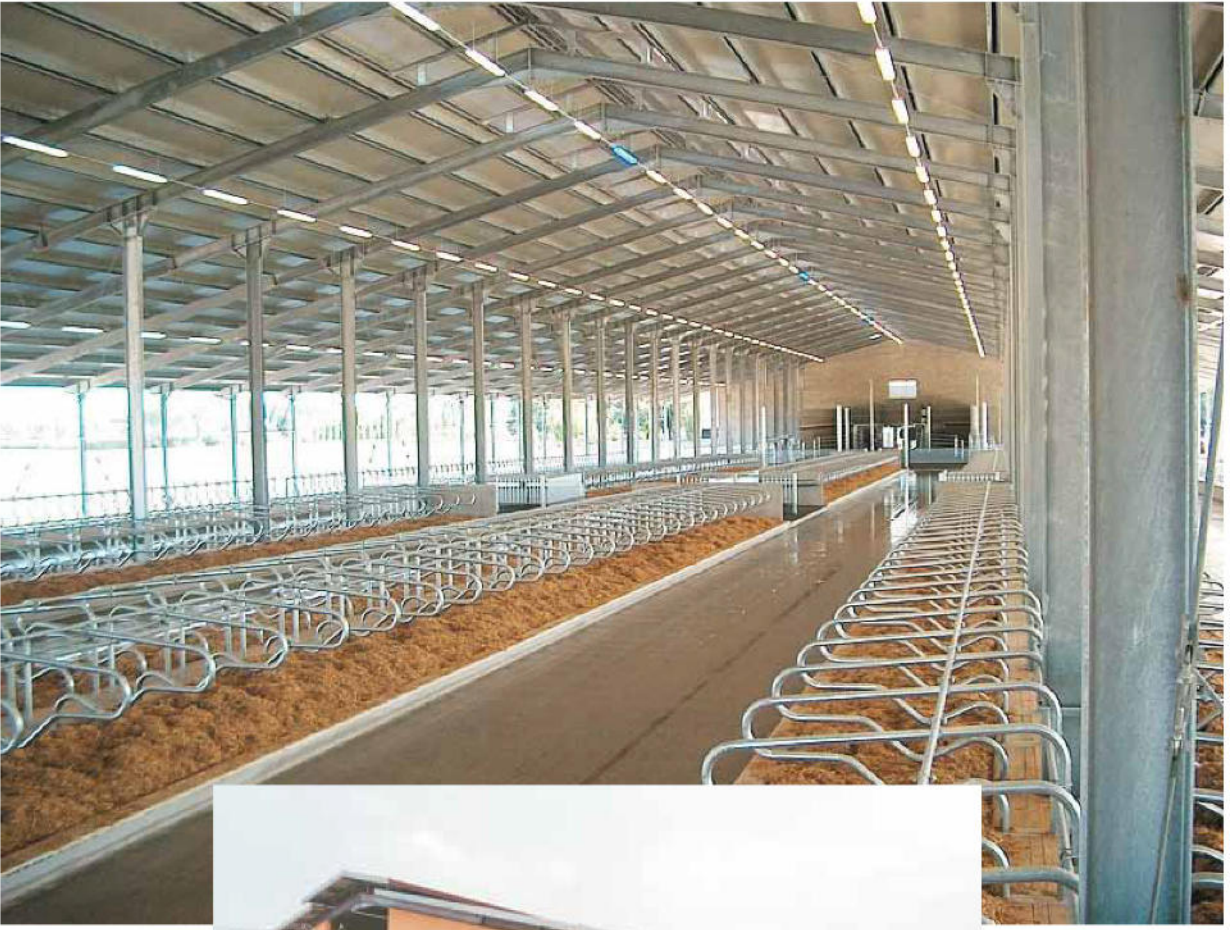





**ENTERPRISE AND DEVELOPMENT TRADE COMPANY srl**

Mobile 335.6452864 - [www.enterpriseanddevelopment.com](http://www.enterpriseanddevelopment.com)



**agriculture equipment**





# greenhouses and equipments



## Hot air generators and Fans







# greenhouses and equipments







# greenhouses and equipments



SERIE 8000  
**RACCOGLITRICE  
SEMOVENTE  
SU RUOTE  
SELF-PROPELLED  
HARVESTER**



- Trasmissione idraulica-meccanica su quattroaapporti per massima potenza a tutte le velocità di lavoro minime/massime.
- Controllo dell'altezza lama-taglio con sensori proporzionali regolabili dalla colonna guida in due impostazioni di taglio: parallelo o differenziato a destra o sinistra.
- Predisposizione per il montaggio della tavola scuotitrice mod. Selecta al fine di selezionare il prodotto da eventuali corpi estranei in fase di raccolta.
- Motore Kubota certificato CARB.
- Larghezze di lavoro: 120-130-140-150-160-170-180 cm.
- Sistema di taglio a lama-nastro a 4 pulegge con luce libera di 38 cm in acciaio inox.







AGROSTAR:  
LEADER NEL DRENAGGIO SOTTERRANEO

NATA NEL 1977,  
E' SPECIALIZZATA IN AGROTECNOLOGIE  
INNOVATIVE



EFFICIENZA  
AUTOMAZIONE  
UNIFORMITÀ

DECINE DI  
MIGLIAIA DI ETTARI  
DI DRENAGGIO  
REALIZZATI  
IN TUTTA ITALIA



# irrigation







# irrigation



**Serie IV**

**Idraulici**





## Applicazioni speciali



## Accessori

# gruppi motopompa



irrigation



irrigation

# MOTOPOMPE



### DEUTZ - SPECK

l/min 5.000 / 8.400  
m 15 / 12



### IVECO MOTORS - ROVATTI

l/min 10.000 / 15.000  
m 21 / 15



### JOHN DEER - ROVATTI

l/min 2.500 / 3.500  
m 161 / 140



### PERKINS - SAER - STAMFORD

l/min 21.000 / 3.800  
m 42 / 36  
KVA 22,5



# ELETTROPOMPE

## ROVATTI

l/min 1.000 / 1.650  
m 242 / 188



## IRCEM

l/min 150 / 500  
m 180 / 122



## CAPRARI

l/min 1.440 / 3.600  
m 96 / 68



## ROVATTI

l/min 1.600 / 3.500  
m 109 / 66



## VARISCO

l/min 3.000 / 6.500  
m 19 / 10

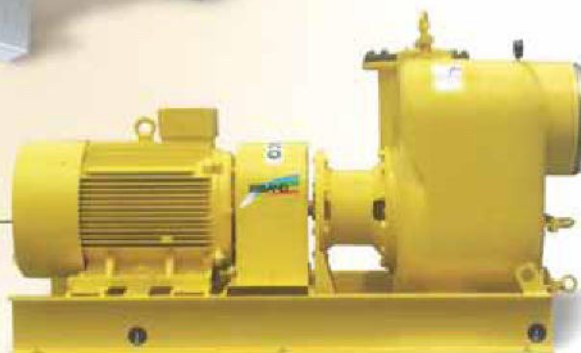

irrigation







# irrigation

## P120 - P105 - P84



### BERICO P120 - P105

P 120						
Ø	VELOCITÀ velocità ft/min	PRESSIONE pressione psi	PORTATA capacità capacidad gpm	GIUNTA long. tubo ft	SPERENZA MEDIA media vida years	SPERENZA MEDIA media vida years
mm	mm	ATA (kg/cm²)	l/min	m	mes	mes
36	6	33,4	65	13266	9,1	
	7	36,3	70	15388	8,5	
	8	39	75	17662	7,9	
38	7	40,5	72	16277	8,9	
	8	43	78	19103	8,1	
	9	46	82	21113	7,8	
40	7	44,8	75	17662	9,1	
	8	48	80	20096	8,6	
	9	50	83	21631	8,3	
42	7	50	76	18136	9,9	
	8	52,8	81	20601	9,2	
	9	56	84	22155	9,1	

P 105						
Ø	VELOCITÀ velocità ft/min	PRESSIONE pressione psi	PORTATA capacità capacidad gpm	GIUNTA long. tubo ft	SPERENZA MEDIA media vida years	SPERENZA MEDIA media vida years
mm	mm	ATA (kg/cm²)	l/min	m	mes	mes
28	4,5	17,5	49	7540	9,3	
	5	18,5	42	8491	7,8	
	5,5	19,4	54	9157	7,6	
30	5	21,0	52	8491	8,9	
	5,5	22,1	55	9499	8,4	
	6	23,0	57	10202	8,1	
32	5,5	25,2	55	9499	9,5	
	6	26,4	58	10562	9,0	
	6,5	27,5	61	11684	8,5	
34	5,5	28,5	57	10202	10,0	
	6	30,0	61	11684	9,2	
	7	32,5	64	12884	9,0	

Irrigatore a lunga gittata e grande portata, adatto per impianti d'irrigazione a pioggia ad alte pressioni, funzionamento meccanico, rotazione a giro completo e settori regolabili.

Raingun of great discharge and long throw. It is particularly suitable for high pressure irrigation systems. It operates mechanically and rotates over a full or part circle.



### BERICO P64 - P4

Irrigatore a media gittata, adatto per impianti d'irrigazione a pioggia a medie pressioni, funzionamento meccanico, rotazione a giro completo e settori regolabili.

Raingun of medium discharge. It operates mechanically and rotates over a full or part circle. Its moving parts are completely protected from the action of the water.

Aspersore de media capacidad. Funcionamiento mecánico. Gira con vuelta completa y con sectores de extensión variable. Sus organos de movimiento son completamente protegidos da la acción del agua.

P 64						attacco F2"
Ø	VELOCITÀ velocità ft/min	PRESSIONE pressione psi	PORTATA capacità capacidad gpm	GIUNTA long. tubo ft	SPERENZA MEDIA media vida years	SPERENZA MEDIA media vida years
mm	mm	ATA (kg/cm²)	l/min	m	mes	mes
16/6	3	5,25	28	2460	7,7	
	4	6,02	32	3215	6,8	
18/6	5	6,77	35	3846	6,3	
	3	6,73	32	3215	7,5	
	4	7,85	35	3846	7,3	
20/8	5	8,68	38	4534	6,9	
	3	8,96	34	3631	8,9	
	4	10,45	37,5	4414	8,5	
22/8	5	11,34	40,5	5150	7,9	
	4	11,75	39	4776	8,8	
	5	13,15	43	5809	8,1	
	6	14,40	45,5	6500	7,9	

P 4						attacco F1" 1/2
Ø	VELOCITÀ velocità ft/min	PRESSIONE pressione psi	PORTATA capacità capacidad gpm	GIUNTA long. tubo ft	SPERENZA MEDIA media vida years	SPERENZA MEDIA media vida years
mm	mm	ATA (kg/cm²)	l/min	m	mes	mes
12	2,5	2,5	22	1250	7,2	
	3	2,63	23,5	1430	6,6	
	3,5	2,84	25	1622	6,3	
14	3	3,58	24,5	1560	8,2	
	3,5	3,85	26	1756	7,9	
	4	4,12	28	2036	7,2	
16	3	4,67	26	1756	9,5	
	3,5	5,05	28	2036	8,9	
	4	5,40	29,5	2260	8,6	
18	3,5	6,30	30,5	2416	9,3	
	4	6,75	31	2496	9,7	
	4,5	7,20	32	2660	9,7	



**GRUPPI DI SPINTA ANTINCENDIO A NORMATIVA UNI 9490**

**FIRE FIGHTING UNITS IN COMPLIANCE WITH THE ITALIAN RULE UNI 9490**

**GROUPE ANTINCENDIE AUX NORMES REQUISES PAR LES RÈGLEMENTS ITALIENS UNI 9490**

**FEUERLÖSCHERANTRIEB NACH, "UNI 9490" NORM**

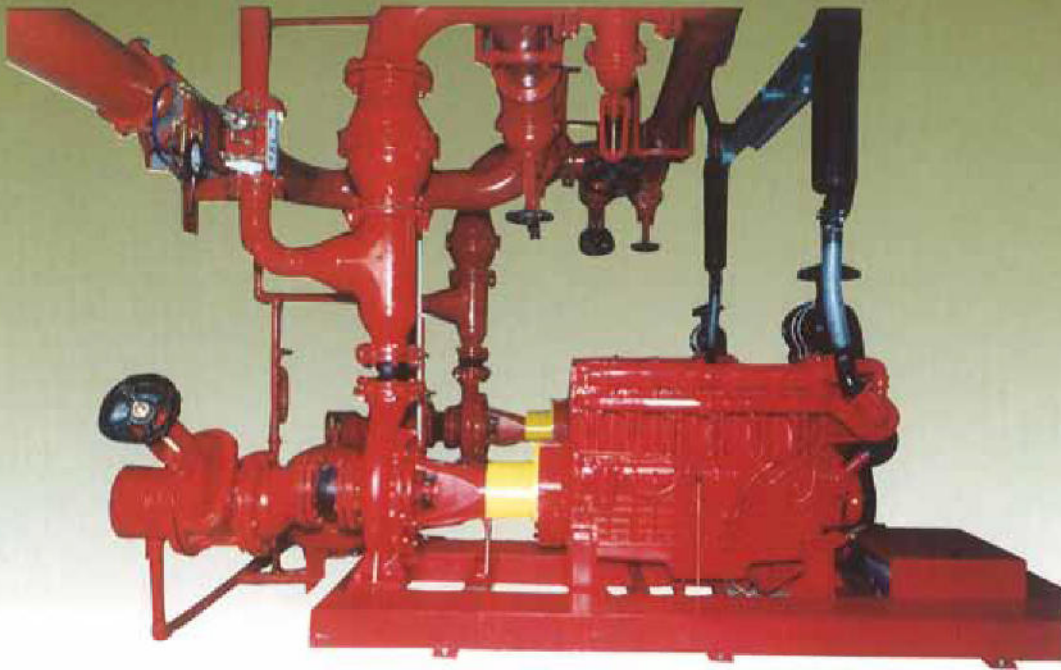

**GRUPPI AUTODESCANTI PER SERVIZIO AGRICOLO, EDILE E INDUSTRIALE  
SELF-PRIMING PUMPSETS FOR AGRICULTURAL, FIRE FIGHTING  
AND INDUSTRIAL SERVICES**

**GROUPES AUTOAMORÇANTS POUR L'EMPLOI DANS LE DOMAINE AGRICOLE,  
DU BÂTIMENT ET INDUSTRIEL**

**SAUGPUMPE FÜR LANDWIRTSCHAFTLICHEN, BAULICHEN  
UND INDUSTRIELLEN GEBRAUCH**



**irrigation**







**GRUPPI ELETTROPOMPE PER SERVIZIO AGRICOLO, INDUSTRIALE E ANTINCENDIO**  
**ELECTRIC PUMPSETS FOR AGRICULTURAL, FIRE FIGHTING AND INDUSTRIAL SERVICE**  
**GROUPES ÉLECTROPOMPES POUR L'EMPLOI DANS LE DOMAINE AGRICOLE,**  
**INDUSTRIEL ET DE L'ANTINCENDIE**  
**ELEKTROPUMPEN FÜR DEN LANDWIRTSCHAFTLICHEN, INDUSTRIELLEN**  
**GEBRAUCH UND DEN FEUERSCHUTZ**



**irrigation**

**GRUPPI MOTOPOMPA PER USO AGRICOLO CON COFANATURA A NORMA "CE"**  
**MOTOR PUMPSETS GROUPS FOR AGRICULTURAL EMPLOYMENT WITH SOUND-REDUCING**  
**CASE IN COMPLIANCE WITH THE EEC DIRECTIVES**  
**MOTOPOMES POUR L'EMPLOI DANS LE DOMAINE AGRICOLE AVEC CAPOT**  
**POUR REDURE LE BRUIT AUX CONDITIONS REQUISES PAR LES DIRECTIVES CEE**  
**MOTORPUMPEN FÜR LANDWIRTSCHAFTLICHEN GEBRAUCH**  
**MIT NACH EWG- NORMEN SCHALLDICHEM SCHUTZBLECH**





Pompe a Pistoni per  
Alta Pressione

High Pressure  
Plunger Pumps



Pompe a Membrana  
e a Pistoni

Diaphragm and  
Plunger Pumps

Vertical multistage  
electric pumps



MEKVX

- Vertical multistage electric pumps entirely in AISI 316 microcasted stainless steel with flanged in-line ports and IEC motor support.

Waste water electric  
submersible pumps



RHV

- Professional electric submersible pumps with vortex impellers for free wet installations or with automatic connection foot.

Vertical lineshaft pumps



V

- Vertical lineshaft pumps with flanged drive head for electric motors, with horizontal right angle gear, with overgear driven by tractor p.t.o and with vertical pulley.



Tractor Driven & Engine Mounted  
Centrifugal Pumps

irrigation







# irrigation

## POMPE CENTRIFUGHE CON MOLTIPLICATORE PER TRATTRICI - SERIE NT CENTRIFUGAL PUMP WITH OVERGEAR FOR TRACTORS - SERIE NT BOMBA CENTRIFUGA CON MULTIPLICADOR PARA TRACTORES - SERIE NT

Le pompe SERIE NT collegate a mezzo albero cardanico alla presa di forza di trattori da 18 a 180CV, sono ideali per l'impiego su impianti di irrigazione a pioggia. Le pompe SERIE NT sono sinonimo di qualità per l'alto rendimento e sicurezza di funzionamento. Sono costruite in più modelli che, con la vasta gamma di rapporti disponibili, consentono una precisa utilizzazione per qualsiasi tipo di trattore nazionale ed estero.

### CONSTRUZIONE:

- Moltiplicatore di giri costituito da una coppia di ingranaggi cilindrici a denti elicoidali supportati da cuscinetti di adeguata robustezza.
- Lubrificazione a bagno d'olio
- Raffreddamento a circolazione d'acqua
- Pompa centrifuga a uno o due giranti
- Giranti in ghisa equilibrati dinamicamente montati su alberi cromati e rettificati onde consentire una lunga durata della tenuta a baderna regolabile.

The NT SERIES pumps, being connected by universal joint to the pto of tractors from 18 to 180 CV, are ideal in every irrigation system. The NT SERIES pumps are a synonymous with quality for its high efficiency, the precise construction and the safety in operating. The pumps are produced in various different models and with its wide range of gears available match perfectly any type of tractor.

### CONSTRUCTION:

- Overgear made by a couple of cylindrical gears with helical teeth mounting on well-dimensioned ball bearings.
- Lubrication by oil bath
- Water - circulation cooling system
- Centrifugal pump with 1 or 2 impeller
- Cast iron impellers dynamically balanced mounted on chromed shafts to allow a long life to the adjustable packed gland.

Las bombas SERIE NT, juntadas por medio de el eje de cardán a la toma de fuerza de tractores desde 18 hasta 180 CV, son ideales para el uso en instalaciones de riego por aspersión. Las bombas SERIE NT son sinónimos de calidad por sus alto rendimiento, la esmerada ejecución y la seguridad de funcionamiento, las bombas son construidas en varios modelos, y con la vasta gama de relaciones permiten una precisa utilización para cada tipo de tractor.

### CONSTRUCCIÓN:

- Multiplicador de vueltas constituido de un par de engranajes cilíndricos de dientes helicoidales montados sobre cojinetes de bolas sumamente resistentes
- Lubricación en baño de aceite
- Refrigeración por circulación de agua
- Giradores en fundición potencialmente equilibrados, montados sobre un eje cromado y rectificado para permitir una larga duración del retén.



Pompa monogirante



Pompa a due giranti



Pompa su base con pompo manuale di adescamento





**Our characters:**

1. Unique initiative tracking system is first choice for walking, to reduce roll-over. The widely used passive tracking system (acting as second choice), gets started under emergency. By this dual-guarantee, the machine can have more smooth operation;
2. Mobile controlled detection: Start-up and stop, running state and live data can be detected & controlled by mobile through GSM. (Live data include: live photos , voice, temperature, moisture, soil temperature, soil moisture, wind speed, wind direction, sunlight intension, rainfall, crop stem size and fruit size. Optional for water pressure & flow rate, pump voltage & current flow and anti-theft alarm);
3. Improve machine performance and irrigation management by minimal investment;
4. Complete safety marks.



irrigation pipe







# irrigation pipe



display for the round drippers

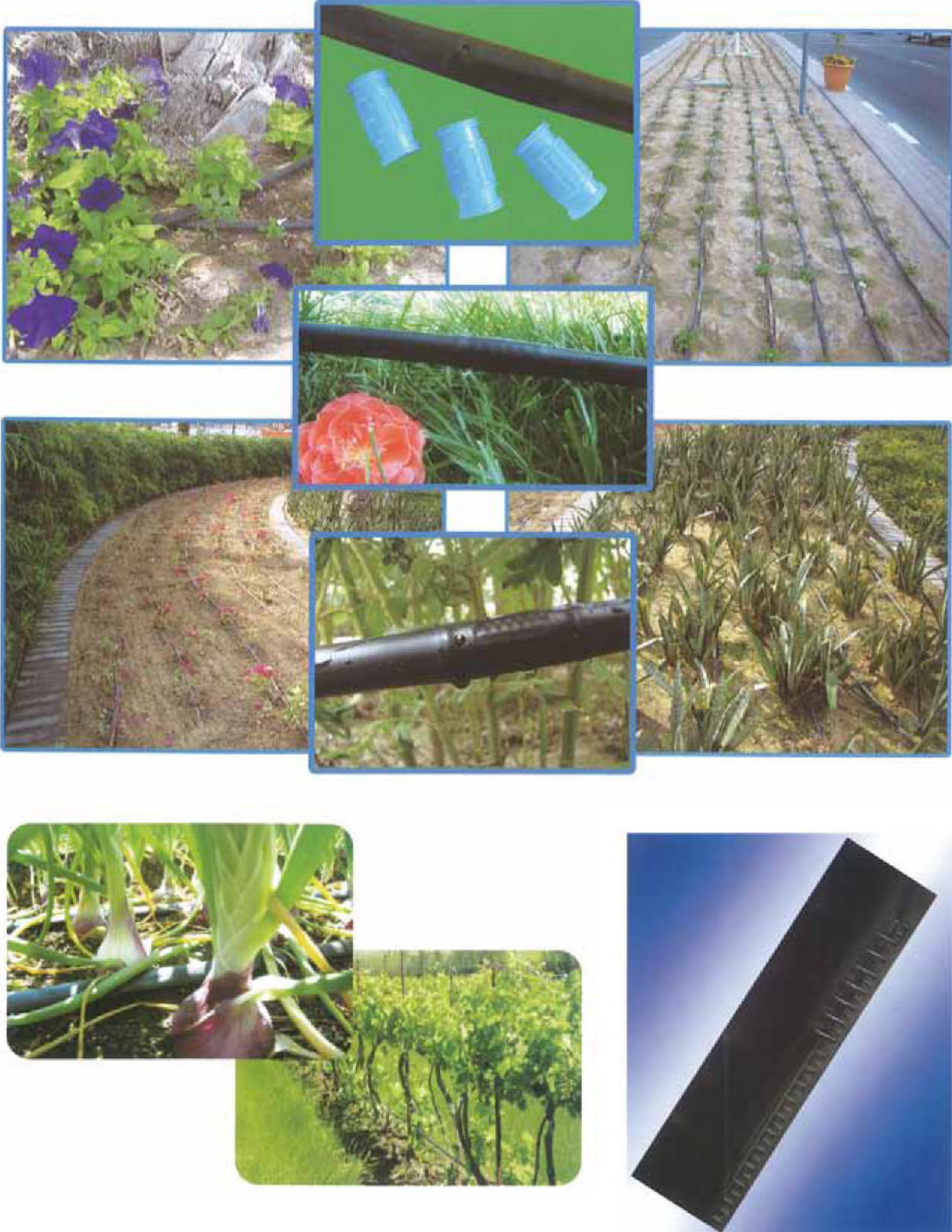





# irrigation pipe



**Lider mundial en cobertura total / World Wide leader in coverage set system**



**Leader mondial de couverture / Weltweiter Marktführer in Flächenbewässerung**







# irrigation pipe

SILVER

3



SILVER 82/200  
+A-0018+A-0189  
+U-176-043



SILVER 82/200  
+A-0018+A-0189  
+U-176-043



SPORT 75/170  
+A-0177

IRRILAND

SILVER



SILVER

3



SILVER 75/170  
+A-0177



SILVER 63/210  
+A-0293+U-176-043



SILVER 63/210  
+A-0293+A-0102  
+A-0077+U-176-043

irrigation pipe

SILVER

3







# irrigation pipe



## VERLEGEMASCHINEN FÜR TROPFROHRE

NETAFIM Verlegemaschinen ermöglichen ein schnelles und komfortables Auslegen und Einholen von Tropfrohren aus dem Feld. Der Einsatz dieser schlagkräftigen Maschinen spart dem Anwender Zeit und erhöht dadurch die Effizienz des Tropfsystems.



## UNSER SERVICE

Dank weltweiter Erfahrung im Bereich Tropfbewässerung besitzt NETAFIM das notwendige Fachwissen, um Sie bei der Projektplanung, Installation von Tropfbewässerungssystemen, Mitarbeiter-Schulung, Technische Beratung, Ersatzteilservice zu unterstützen.

Falls Sie Fragen zu unserem Service haben wenden Sie sich bitte an Ihren NETAFIM-Partner. NETAFIM gewährleistet auf alle Produkte eine entsprechende Herstellergarantie.





# food industry

**ENTERPRISE AND DEVELOPMENT TRADE COMPANY srl**

Mobile 334.8204934 - [www.enterpriseanddevelopment.com](http://www.enterpriseanddevelopment.com)





# food industry



Accurate and secure control of the climate



Less weight loss and free ambient cooling with Mooij Humidicells







Mooij Aspiration system  
for open bins.  
Cooling the crop  
not the room



Optimal air distribution  
with Mooij half-  
round ducts



food industry





# food industry

## Custom solutions from the refrigeration specialist that has been setting the standard for years

cold storage engineering - refrigeration engineering - electrical engineering - control engineering

We've developed several innovative, new solutions over the years that have gone on to become industry standards. We're particularly proud of this achievement and as a customer, you'll be relieved to hear that you're doing business with the company that conceived **Gisopanel®** and **Gisdoor®**.

### Cold storage engineering

#### **Gisopanel®** insulation panels

For decades, the standard in insulation panels. High levels of insulation and vapour-proof assembly by in-house personnel are guarantees for energy-efficiency.

#### Benefits:

- Rigid panelling structure does away with need for costly, steel frameworks.
- Fire retardant materials used in a variety of ways.
- Designed with hygiene in mind to satisfy HACCP and BRC standards for food processing industry, e.g. half-round fillet section, chamfered window sills, sanitary kits, food safe coatings and use of stainless steel.

#### **Gisdoor®** access technology

Indestructible, intelligent and easy-to-operate doors for cold stores and freezer stores.

#### Benefits:

- Available in several versions – brush, panel, sliding and rotating doors.
- Custom-made in all sizes – manual or automatic operation.
- Smooth operation and easy to close running on upper or lower rails.
- Unique, insulated **Gisopanel®** hatches.
- Virtually indestructible, heavy-duty hinges.
- Precision PLC control and operation.
- Ideal for airing certain tuberous crops in the open air.





# DAIRY FIELD

## MACHINES

- TANKS
- MILK RECEIVING GROUPS
- ESL, UHT, PASTEURIZATION PLANTS
- CENTRIFUGAL SEPARATORS
- HOMOGENIZERS
- DEGASSERS/DEODORIZERS
- COAGULATION VATS
- CURD DRAINAGE AND FILLING SYSTEMS
- PRE-PRESSING AND PRESSING SYSTEMS
- SOFT, SEMI-HARD AND HARD CHEESE, RICOTTA AND YOGHURT PRODUCTION LINES
- RIPENING TANKS
- MINI DAIRY PLANTS
- SALTING PLANTS
- CIP/SIP PLANTS
- MEMBRANE FILTRATION PLANTS
- RIPENING ROOMS



Priamo boasts many years of experience in the sector. The milk-dairy industries ought to have suitable materials and instruments for foodstuffs as well as a particular technical sensitivity and

care in treating and handling the milk and its derivatives in order to ensure that the taste and fragrance remain the same.



# food industry







# food industry



ETICHETTATRICI,  
TAPPATRICI,  
RIEMPITRICI,  
CONFEZIONAMENTO







LA FRUTTA PER LO YOGURT  
I PREPARATI PER I DESSERT  
LE ETICHETTE PER I VASETTI



**PERSONALIZE YOUR CONTAINER IN 2 MOVES**

CHOOSE THE CONTAINER    SEND US YOUR LOGO

**COSA PUOI PRODURRE**  
YOGURTIERA AUTOMATICA POLIVALENTE

MOZZARELLA  
SCAMORZA  
STRACCHINO

LATTE ALIANTANE  
YOGURT NATURALE  
FORMAGGIO FUSO

PANNA COTTA  
BAMBOLINI PER GELATO  
CADDIE



food industry







## Production lines for fruit and vegetable puree

### Process description

Boema manufactures complete plants for natural or concentrated fruit and vegetable puree prepared for aseptic packaging, or freezing and to the production of juices, mixtures and jams.

There are two different process technologies for puree production.

Boema offers, for each one of these technologies, the more suitable solution: as a result of experience developed over several working years.

The proposed Boema technologies are:

1. Hot puree extraction
2. Cold puree extraction

#### "Hot" puree extraction:

In general, this technology is conceived for reducing the whole raw material (without stone) in quite small pieces (from 10 to 30 mm. each), produced by a hammer pulping machine; while the fruits with stones are sent to a roller destoner, which separates the fruit pulp. In this phase, it is also possible, even necessary, to perform the product pH correction according to the required parameters and needs. The crushed pieces or the pulp obtained are conveyed inside the heating unit, which performs the enzymatic inactivation. After that, the puree will be separated from peel and from scraps by the refining process. For the enzymatic inactivation and the heating, Boema suggests the following equipments:

- Indirect steam heaters by means of rotating coil
- Tubular heaters.

Of these systems, the heater proposed by Boema for the production of vegetables puree (of carrots, celeriac, beetroot, etc.), is working with indirect steam by means of horizontal rotating coil. The tubular heater, alternatively, is better conceived for fruit puree production.

#### "Cold" puree extraction:

This kind of process is designed to reduce the product to pulp or in crushed pieces and for the puree extraction immediately after with a specific extractor. The puree obtained is always conveyed inside a tubular heating system with product recycle for the further enzymatic inactivation treatment.

This kind of process is specially conceived for fruits, in particular for apples. In fact, it mainly preserves the product against further "colour transfers" between the skin and the pulp and avoids any risk of product pollution given by pesticides, as the peel is already removed before the heating process.

### Receiving, washing and inspection



Bin tipper



Washing machine with agitating action complete with filtration unit for the washing water



Washing and destoning monoblock for vegetables



Sorting belt with conveyors for waste

### First processing



Hammer pulping machine for fruits without stone and vegetables



Roller destoner



Stones cleaner with transfer pump for the recovered pulp



Crushing unit with "cold" extractor





## Enzymatic deactivation



Tube nest quick heating unit



Horizontal through heater with rotating coil



Tube nest tubular heater with one principle (brovatrice)



"Hot break" vacuum tube nest heater

## Final processing



Puree refining unit



Forced circulation evaporator



Degassing unit



Tubular sterilizer for puree prior to aseptic packaging

food industry





# Pre-fried potato production line



food industry



03- Lavatrice a tamburo  
03- Drum washing machine



06- Pelatore a pressione di vapore  
06- Pressure steam peeler

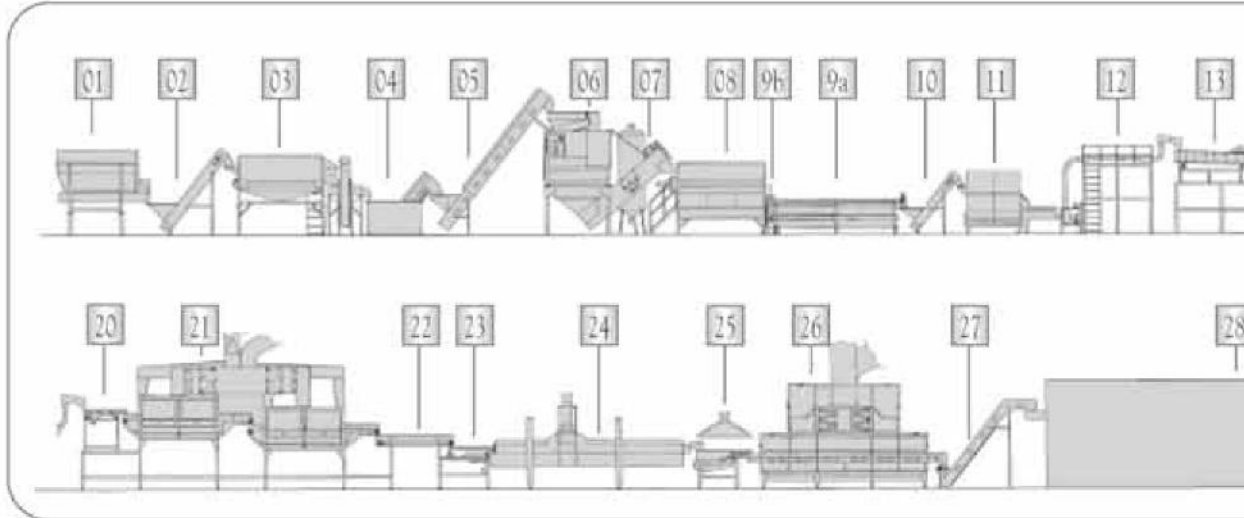

17/18- Gruppo di blancheratura per scioglimento zuccheri e gelatinizzazione amido  
17/18- Blanching unit to dissolve sugar and gelatinize starch



20/22- Gruppo di preessiccazione e stabilizzazione  
20/22- Pre-drying and stabilizing unit





# Linea di produzione Patate Prefritte

## Pre-fried potato production line

01/15: Gruppo di preriscaldamento, taglio, calibratura e cernita ottica  
01/15: Preheating, cutting, sizing and optical sorting unit

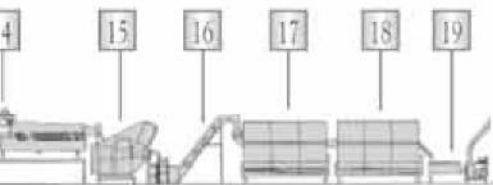

Al confezionamento  
to the packaging

- |   |   |   |
|---|---|---|
| 01- primone dotatore                      | 20- sgranatore vibrante                     | 96- scraps removal system                 |
| 02- elevatore                             | 21- pressiccatario                          | 10- elevator                              |
| 03- lavatrice a tamburo                   | 22- nastro di stabilizzazione               | 11- preheater                             |
| 04- spazzatrice gravitazionale            | 23- piano vibrante di carico<br>friggitorie | 12- hydro cut                             |
| 05- elevatore                             | 24- friggitorie                             | 13- vibrating table for scraps<br>removal |
| 06- pelatore a vapore                     | 25- piano vibrante di sgranatura<br>olio    | 14- roller sizing table                   |
| 07- vasca con coclea di estrazione        | 26- preraffreddatore                        | 15- optical sorter                        |
| 08- spazzatrice - lavatrice               | 27- elevatore                               | 16- in-tank elevator                      |
| 09- nastro di cernita a rulli             | 28- surgelatore continuo                    | 17- drum blancher                         |
| 90- sistema di evacuazione<br>scarti      |   | 18- drum blancher                         |
| 10 - elevatore                            |   | 19- hydraulic transport                   |
| 11- preriscaldatore                       | 01- plenum blancher                         | 20- drainage vibrating table              |
| 12- taglio ad acqua                       | 02- elevator                                | 21- preheater                             |
| 13- piano vibrante di rimozione<br>stridi | 03- drum washing machine                    | 22- stabilization belt                    |
| 14- calibratore a rulli                   | 04- gravitational stoner                    | 23- vibrating table for fryer<br>loading  |
| 15- cernitrice ottica                     | 05- elevator                                | 24- fryer                                 |
| 16- elevatore in vasca                    | 06- steam peeler                            | 25- vibrating table for oil<br>dripping   |
| 17- blancher a tamburo                    | 07- tank with extraction<br>screw           | 26- precooler                             |
| 18- blancher a tamburo                    | 08- brush-washer                            | 27- elevator                              |
| 19- trasporto idraulico                   | 90- roller sizing belt                      | 28- continuous outgator                   |



23/25- Friggitorie con piano vibrante di alimentazione e piano vibrante di sgranatura  
23/25- Fryer with feeding vibrating table and vibrating table for oil dripping



24- Particolare dell'interno friggitorie  
24- Detail of fryer inside

food industry





# weighing technology

**ENTERPRISE AND DEVELOPMENT TRADE COMPANY srl**

Mobile 334.8204934 - [www.enterpriseanddevelopment.com](http://www.enterpriseanddevelopment.com)





### Model TS-300

The TS 300 is our basic model. It unites ease of use with the reliability, precision and quality that characterize the Tecno System company's range of products. It is the ideal model for those who require the basic functions of accurate weighing.

It allows for the programming of 5 recipes with 15 ingredients, to be loaded or unloaded, and allows for manual weighing with threshold. Excellent visibility of the display and the keyboard allows for ease of use even in badly lit areas. It is preset for remote radio control and for a remote ancillary display (repeater).

### Model TS-3500

The TS 3500 is the most widely used model in the Tecno System product range. It is designed for those who require the very best weighing solutions. It allows for the automatic handling of the entire loading, mixing and unloading cycle. It is also preset for the exchange of data with a Personal Computer.

It can be programmed with up to 30 recipes with 25 ingredients, 4 mixing times and 5 unloading fractions. It manages programming per number of animals and consumption totalizers. The display is the same size as the one on the TS-300 and therefore allows for ease of use even in badly lit areas. This model is preset to be used with a radio control, a remote ancillary display (repeater), a printer and interface with a Personal Computer.



	TS-300	TS-3500
Power supply	10-18V dc	10-18V dc
Absorbed power	3W (incl. accessories)	3W (incl. accessories)
Protection	Electronic fuse	Self-resetting electronic fuse of 0.75A
Working Temperature	from -20 °C to +50 °C	from -20 °C to +50 °C
Maximum humidity	90% non-condensing	90% non-condensing
Power supply of loading cells	8.5V (max 6 cells of 350 Ohm)	8.5V (max 6 cells of 350 Ohm)
Alarm output	max 1A	max 1A
Micro controller	80x, 16x80	80x, 16x80
Converter	Sigma-delta, 65536 points	Sigma-delta, 65536 points
Memory	Permanent ferroelectric	Sigma-delta, 65536 points
Display	6 figures, 1440nm, electroluminescent	6 figures, 1440nm, electroluminescent
Keyboard	6 membrane keys	12 membrane keys
Casing	Aluminium, protection factor IP65	Aluminium, protection factor IP65

weighing technology







# weighing technology







weighing technology

note





A series of horizontal dotted lines for taking notes.

## *Partners*

---





# from **ITALY** to the **WORLD**

Con 25 ANNI di esperienza, la Enterprise and Development Trade company, è leader nello sviluppo delle relazioni commerciali tra moltissime aziende italiane produttrici di qualità e distributori di tutto il mondo.

**crediamo in quello che facciamo!**

*With 25 YEARS experience the Enterprise and Development Trade Company, is leader in developing relations and business between italian quality producers and trader all over the world.*

*we trust in what we do!*



**ENTERPRISE AND DEVELOPMENT**

**TRADE COMPANY srl**

di Figaroli Girolamo & C.

Via Garibaldi, 36

25010 ISORELLA (BS) ITALY

Mobile 334.8204934

[info@figaroligirolamo.com](mailto:info@figaroligirolamo.com)

Skype: Figaroli Girolamo

[www.enterpriseanddevelopment.com](http://www.enterpriseanddevelopment.com)